

ने.गुण. ४०:२०७९
NS 40:2022



नेपाल गुणस्तर
NEPAL STANDARD

Polyethylene Pipes for Water Supply - Specification



Government of Nepal
Ministry of Industry, Commerce and Supplies
Nepal Bureau of Standards and Metrology (NBSM)
Kathmandu, Nepal

www.nbsm.gov.np

© Nepal Council for Standards (NCS), 2020

All rights reserved. Unless otherwise specified, or required in the context of its implementation, no part of this publication may be reproduced or utilized otherwise in any form or by any means, electronic or mechanical, including photocopying, or posting on the internet or an intranet, without prior written permission. Permission can be requested from NBSM at the address below.

Nepal Bureau of Standards and Metrology

Balaju, Kathmandu, Nepal

Phone: +977 1 4350445/4350818

Email: info@nbsm.gov.np

Website: www.nbsm.gov.np

Table of Contents

Table of Contents	II
Foreword.....	III
1. SCOPE.....	1
2. REFERENCES	1
3. TERMINOLOGY.....	2
4. GRADE OF RESIN	4
5. MATERIAL	4
6. PIPE DESCRIPTION	6
7. GEOMETRIC CHARACTERISTICS OF PIPE.....	7
8. PERFORMANCE REQUIREMENTS	9
9. SAMPLING, FREQUENCY OF TESTS AND CRITERIA FOR CONFORMITY	12
10. MARKING.....	15
ANNEX A	16
ANNEX B.....	17
ANNEX C	18
ANNEX D	20
ANNEX E.....	22
ANNEX F.....	23
ANNEX G	24
ANNEX H.....	27
ANNEX J	33

Foreword

NBSM (Nepal Bureau of Standards and Metrology) is the National Standard Body involved in the development of standards in the country. The standard development process involves committee consisting of multi-stakeholders both from public and private sectors.

This standard is developed by technical committee having multi-stakeholder participation and approved by Nepal Standard Council as per Nepal Standard (Certification) Act, 1980.

This standard is based on ISO 4427 -1:2007 'Plastic piping systems – Polyethylene (PE) pipes and fittings for water supply – Part1: General', ISO 4427 -2:2007 'Plastic piping systems – Polyethylene (PE) pipes and fittings for water supply – part 2 : Pipes' and IS 4984 :2016 – Polyethylene Pipes for Water Supply – Specification' with some deviations.

This standard replaces NS 40: 2042 (fourth revision) and includes new raw material, pipe sizes range expansion, added performance requirements and some test methods. The standard will benefit both the users and the producers to have product of appropriate design and dimension; and will provide assurance of quality of the products as well.

The standard covers materials, design and dimension, tests, and sampling requirements.

This standard contributes towards fulfilment of SDG goals.

Attention is drawn to the possibility that some of the elements of this document may be the subject of patent rights. NBSM shall not be held responsible for identifying any or all such patent rights. Any trade name used in this document is information given for the convenience of users and does not constitute an endorsement.

Any feedback or questions on this document should be directed to the user's national standards body. A complete listing of these bodies can be found at www.nbsm.gov.np.

Nepal Standard

Polyethylene Pipes for Water Supply – Specification

1. SCOPE

- 1.1** This standard lays down the requirements for polyethylene (PE) pipes (mains and service pipes) intended for the conveyance of water for human consumption including raw water prior to treatment and also water for general purpose.
- 1.2** This standard is applicable for the water supplies with a maximum operating pressure of 2.0 MPa.
- 1.3** An operating temperature of 27°C has been taken as the reference temperature.
- 1.4** The reference temperature of 20°C for 50 years of continuous stress is considered for the minimum required strength (MRS) of polyethylene base resin. To enable an operating water temperature of 27°C, the design stress has been accordingly corrected (see Table 1 and corresponding Notes). The standard also provides pressure reduction coefficients for water temperatures higher than 20°C and other than 27°C so as to calculate the maximum allowable operating pressure at those temperatures.
- 1.5** This standard does not purport to give guidelines for designing and dimensioning of pipe lines.

2. REFERENCES

- 2.1** The following standards contain provisions, which through reference in this text, constitute provisions of this standard. At the time of publication the editions indicated are valid. All standards are subject to revision and parties to agreement based on this standard are encouraged to investigate the possibility of applying the most recent editions of the standards indicated below :

NS... , Determination of water – Karl Fischer method (General method)

NS 97, Methods of test for polyethylene moulding materials and polyethylene compounds (melt flow rate)

NS 145, Methods of random sampling

NS 110, High Density polyethylene materials for moulding and extrusion — specification (first revision)

NS..., Method of analysis for the determination of specific and/or overall migration of constituents of plastics materials and articles intended to come in contact with foodstuffs

NS....., Positive list of constituents of polyethylene in contact with foodstuffs, pharmaceuticals and drinking water

NS....., Polyethylene for its safe use in contact with foodstuff, pharmaceuticals and drinking water)

3. TERMINOLOGY

For the purpose of this standard, the following definitions shall apply:

- 3.1 Nominal Size (DN)** — Numerical designation of the size of a component, other than a component designated by a thread size, which is a convenient round number approximately equal to the manufacturing dimension in millimetres (mm).
- 3.2 Nominal Size (DN/OD)** — Nominal size, related to the outside diameter.
- 3.3 Nominal Outside Diameter (d_n)** — Specified outside diameter, in millimetres, assigned to a nominal size DN/OD.
- 3.4 Outside Diameter at any Point (d_e)** — Value of the measurement of the outside diameter through its cross-section at any point of the pipe rounded to the next greater 0.1 mm.
- 3.5 Mean Outside Diameter (d_{em})** — Value of the measurement of the outer circumference of the pipe or spigot end of a fitting in any cross-section divided by π ($= 3.142$), rounded to the next greater 0.1 mm.
- 3.6 Minimum Mean Outside Diameter ($d_{em, Min}$)** — Minimum value of the outside diameter as specified for a given nominal size.
- 3.7 Maximum Mean Outside Diameter ($d_{em, Max}$)** — Maximum value of the outside diameter as specified for a given nominal size.
- 3.8 Out-of-roundness (Ovality)** — Ovality shall be measured as the difference between maximum outside diameter and minimum outside diameter measured at the same cross-section of the pipe, at 300 mm away from the cut end, for the pipe to be coiled.
- 3.9 Nominal Wall Thickness (e_n)** — Numerical designation of the wall thickness of a pipe, which is a convenient round number approximately equal to the manufacturing dimension in millimetres.
- 3.10 Standard Dimension Ratio (SDR)** — The SDR value is the ratio of the nominal outside diameter, d_n , of a pipe to its nominal wall thickness.

$$SDR = d_n / e_n$$

- 3.11 Wall Thickness at any Point (e)** — Wall thickness at any point of the body of the pipe, around its circumference
- 3.11.1 Minimum Wall Thickness at any Point (e_{Min})** — Minimum value of the wall thickness at any point of the body of the pipe, around its circumference as specified.
- 3.11.2 Maximum Wall Thickness at any Point (e_{Max})** — Maximum value of the wall thickness at any point of the body of the pipe, around its circumference as specified.

- 3.12 Mean Wall Thickness (e_m)** — The arithmetic mean of a number of measurements regularly spaced around the circumference of the pipe in the same cross-section of the pipe, including the measured minimum and the measured maximum values of the wall thickness.
- 3.13 Tolerance** — Permissible variation of the specified value of a quantity expressed as the difference between the permissible maximum and permissible minimum values.
- 3.14 Minimum Required Strength (MRS)** — Minimum value in megapascals (MPa), for long-term hydrostatic strength (LTHS) of the polyethylene resin which represents the 97.5 percent confidence limits of the predicted hydrostatic strength at 20°C for 50 years. This is considered as the property of the material.
- 3.15 Overall Service (Design) Coefficient (C)** — An overall design co-efficient with a value greater than 1, which takes into consideration service conditions as well as properties of the components of a piping system other than those represented in the lower confidence limit. For water supply pipes, the minimum value of C is 1.25.
- 3.16 Design Stress (s)** — The maximum allowable stress, expressed in megapascals (MPa), for a given application derived by dividing MRS by the co-efficient C. This is the allowable stress at 20°C.
- 3.17 Nominal Pressure (PN)** — Numerical designation used for reference purposes related to the mechanical characteristics of the component of piping system.

NOTE — For plastic piping systems conveying water, it corresponds to the maximum continuous operating pressure, expressed in bar which can be sustained with water at 27°C, based on the minimum design coefficient, C (1 MPa = 10 bar).

The relationship between MRS, PN and SDR is given in Annex A.

- 3.18 Maximum Allowable Operating Pressure (MAOP)** — The maximum allowable continuous pressure, expressed in MPa. It is given by the equations,

$$P \text{ (MPa)} = \frac{2 \times \sigma}{[(SDR-1)]} \times f_T$$

$$P \text{ (MPa)} = \frac{2 \times \text{MRS}}{C [(SDR-1)]} \times f_T$$

Where

SDR = standard dimension ratio;

σ = design stress, in MPa;

MRS = minimum required strength, in MPa;

f_T = pressure reduction co-efficient; and

C = overall service design co-efficient.

3.19 Pressure Reduction Co-efficient (f_T) — A co-efficient which takes into account the reduction in maximum allowable operating pressure due to increase in operating temperature.

3.20 Melt Flow Rate (MFR) — Value relating to the viscosity of the molten thermoplastic material at a specified temperature and rate of shear.

3.21 Virgin Material — Thermoplastics material in a form such as granules which has not been previously processed other than for compounding and to which no reprocessed or recycled materials have been added.

4. GRADE OF RESIN

Pipes shall be classified according to the grade of the raw material (resin) as given in Table 1. The resin supplier shall give the raw material grade.

Table 1 Classification of Materials
(Clause 4)

Sl No.	Material Classification (Grade)	MRS (Minimum Required Strength) of PE Resin at 20°C for 50 Year Life MPa	Design Stress at 20°C MPa
(1)	(2)	(3)	(4)
i)	PE 63	6.3	5
ii)	PE 80	8.0	6.3
iii)	PE 100	10.0	8

NOTES

- 1 The maximum allowable operating pressure (MAOP) of a pipe is obtained by the equations given in 3.18.*
- 2 Pressure reduction-coefficients for calculating maximum allowable operating pressure at temperatures higher than 20°C are given in Fig. 1.*
- 3 As an operating water temperature of 27°C has been considered, a pressure reduction co-efficient, f_T , of 0.85 has been taken from Fig. 1 and used in the equation given at 3.18 for determining the maximum allowable operating pressure at 27°C (nominal pressure). This ensures that no further correction factor is required for over ground or underground water supply systems.*
- 4 The wall thicknesses are calculated based on maximum allowable operating pressure at 27°C rounded up to nearest SDR series (PN values). The pressure class (pressure rating) is also rounded to standard series. Tolerances calculated from $(0.1e_{Min}+0.1)$ mm rounded up to the next 0.1 mm. considering operational production problems, maximum wall thickness of pipes are considered around 130 mm.*
- 5 The pipes are recommended for maximum water temperature of +45°C.*
- 6 The pipes may also be used up to the ambient temperature of -40°C without any correction factor as long as the water temperatures inside the pipe do not exceed the operating temperature of 27°C. Intermittent increase in the ambient or water temperatures because of weather changes would not have any deleterious effect on the pipe's long-term performance.*

5. MATERIAL

5.1 General

The material used for the manufacture of pipes should not constitute toxic hazard, should not support microbial growth and should not give rise to unpleasant taste or odour, cloudiness or discoloration of water. Pipe manufacturers shall obtain a certificate to this effect from the manufacturer of raw material.

5.2 Polyethylene Resin

PE resin used for the manufacture of pipes shall conform to parameters mentioned in Table 2. In addition, the resin shall conform to requirement of NS 110.

The material classification and conformity to Table 2 shall be provided by the raw material (resin) manufacturer with documentation duly certified by resin manufacturer.

5.3 Carbon Black Master Batch

Carbon black master batch shall be manufactured from a mixture of the following:

- a) Polyethylene, which may include co-polymers of ethylene and higher olefin, in which the higher olefin constituent does not exceed 10 percent (mass/mass) and density of 910-950 kg/m³.
- b) The constituents used should be from the positive list of constituents of PE, in contact with food stuff, pharmaceutical and drinking water as per NS.... and should not constitute a toxic hazard, shall not support microbial growth and shall not give rise to an unpleasant taste or odour, cloudiness or discoloration of the water.
- c) Loading of carbon black should not exceed 50 percent (m/m).
- d) Ash content <0.1 percent.
- e) Carbon black used in carbon black master batch shall comply with the following requirements:
 - 1) Density: 1.5 to 2.0 g/ml.
 - 2) Toluene extract not more than 0.1 percent (m/m) .
 - 3) Maximum volatile matter 0.9 percent (m/m) (see Annex C).
 - 4) Carbon black particle size should be less than 0.025 μ .

NOTE — A test report or confirmative certificate may be obtained from the carbon black master batch manufacturer.

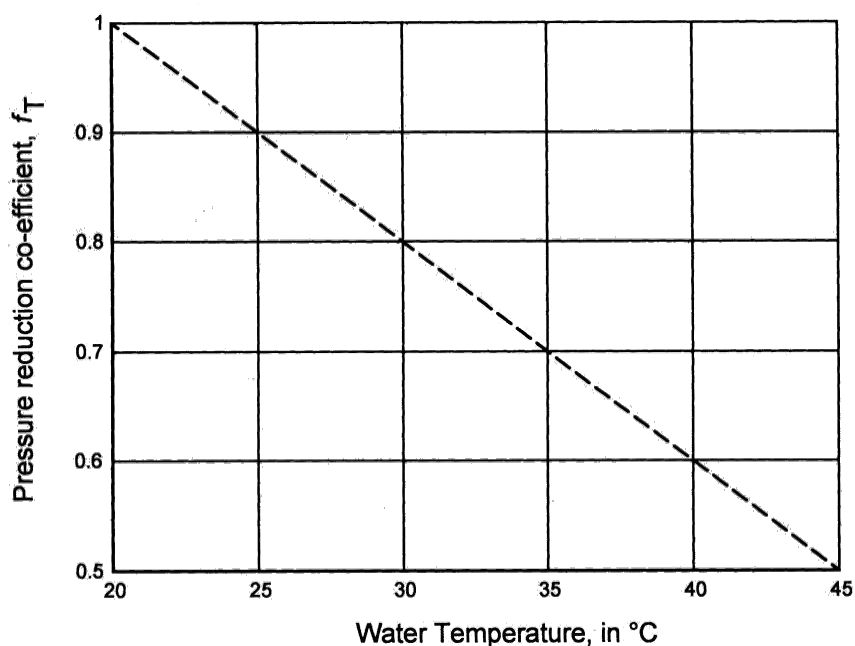

FIG. 1 PRESSURE REDUCTION CO-EFFICIENT FOR WATER TEMPERATURES ABOVE 20°C

Table 2 Characteristics of PE Resin as Granules
(Clauses 5.2 and 6.1.1)

Sl No. (1)	Characteristics (2)	Units (3)	Requirements (4)	Test Parameters (5)	Test Method (6)
i)	Base density	kg/m ³	930-965	27°C	NS 110
ii)	Melt flow rate	g /10 min	0.2 to 1.1 (both inclusive)	190°C using a 5 kg mass	NS 97
iii)	Thermal stability (oxidation induction time)	min	≥ 20	200°C, isothermal	Annex B
iv)	Volatile matter	mg/kg	≤ 350	Number of test pieces	01 Annex C
v)	Water content ¹⁾	mg/kg	≤ 300	Number of test pieces	01 Annex D

¹⁾This requirement is only applicable if the measured volatile content is not in conformity with its specified requirement. In case of dispute, the requirement for water content shall apply. (If the water content exceeds the limit, drying to be done prior to use).

5.4 Anti-Oxidant

The percentage of anti-oxidant used shall not be more than 0.3 percent by mass of finished resin. The anti-oxidant used shall be physiologically harmless and shall be selected from the list given in NS... The raw material supplier shall provide test certificate containing the Anti-Oxidant percentage and the name of the Anti-Oxidant.

5.5 Rework Material

Clean, reprocessible material generated from a manufacturer's own production and works testing of products according to this standard may be used if it is derived from the same raw material as used for the relevant production however it shall not be more than 10%. Reprocessible material obtained from external sources and recycled material shall not be used.

6. PIPE DESCRIPTION

6.1 Pipes shall be designated according to the grade of material (see 6.1.1) followed by pressure rating (PN) (see 6.1.4), nominal outside diameter (see 6.1.3) and standard dimension ratio (SDR) (see 6.1.2), For example PE 80, PN 5, DN 200 SDR 26, indicates pipe pertaining to material grade PE 80, pressure rating 5, nominal outside diameter 200 mm & wall thickness corresponding to SDR 26.

6.1.1 The grade of material shall be as given in Table 1.

6.1.2 The standard dimension ratio of pipes covered in this standard are:

SDR 41, SDR 33, SDR 26, SDR 21, SDR 17, SDR 13.6, SDR 11, SDR 9, SDR 7.4 and SDR 6.

6.1.3 The nominal outside diameter of pipes covered in this standard are:

16, 20, 25, 32, 40, 50, 63, 75, 90, 110, 125, 140, 160, 180, 200, 225, 250, 280, 315, 355, 400, 450, 500, 560, 630, 710, 800, 900, 1000, 1200, 1400, 1600, 1800, 2000 mm.

6.1.4 The pipes shall be classified by pressure rating (PN) corresponding to the maximum allowable operating pressure at 27°C, as follows:

Pressure Rating of Pipe (1)	Maximum Allowable Operating Pressure at 27°C (2)
PN 2	0.20 MPa
PN 2.5	0.25 MPa
PN 3	0.30 MPa
PN 3.2	0.32 MPa
PN 4	0.40 MPa
PN 5	0.50 MPa
PN 6	0.60 MPa
PN 8	0.80 MPa
PN 10	1.00 MPa
PN 12.5	1.25 MPa
PN 16	1.60 MPa
PN 20	2.00 MPa

6.2 Colour

The colour of the pipe shall be black with blue identification stripes.

6.2.1 Identification Stripes

Each black pipe with identification stripes shall contain minimum of three longitudinal stripes of minimum width of 3 mm in blue colour, circumferentially distributed. These stripes shall be co-extruded during pipe manufacturing and shall not preferably be more than 0.2 mm in depth for wall thickness up to 10 mm and 0.5 mm beyond 10 mm. The material of the stripes shall be of the same type as used in the base compound for the pipe.

7. GEOMETRIC CHARACTERISTICS OF PIPE

7.1 Visual Appearance

The internal and external surface of the pipe shall be smooth, clean and free from grooving and other defects. The ends of the pipes shall be cleanly cut square with the axis of the pipe to within the tolerances given below and free from deformity. Slight shallow longitudinal grooves or irregularities in the wall thickness shall be permissible, provided that the wall thickness remains within the permissible limits.

Nominal diameter DN Mm (1)	Maximum Out of Square of Pipe End mm (2)
16 to 75	2
90 to 125	3
140 to 180	4
200 to 280	5
Above 280	7

7.2 Length

The length of straight pipe shall be 5 m to 20 m as agreed to between the manufacturer and purchaser. Short lengths of 3 m (minimum) up to the maximum of 10 percent of the total supply may be permitted.

7.3 Coiling

The pipes shall be coiled such that localized deformation, for example, buckling and kinking is prevented. The minimum internal diameter of the coil shall not be less than 18 d_n . The length of the coiled pipes shall be as agreed between the manufacturer and purchaser.

7.4 Dimensions

The mean outside diameters, d_{em} , and the out-of-roundness (ovality) of the pipes for different nominal diameters covered in the standard shall be in accordance with Table 3. The minimum and maximum wall thickness of pipes shall be as given in Table 4.

7.4.1 Methods of Measurement

7.4.1.1 Mean outside diameter of the pipe shall be the average of two measurements taken using a vernier at right angles for pipes up to 50 mm diameter. For higher sizes, the diameter shall be measured using a flexible Pi tape or a circumeter, having an accuracy of not less than 0.1 mm. The wall thickness shall be measured by a dial vernier or ball ended micrometer. The resulting dimension shall be expressed to the nearest 0.1 mm.

NOTES

- 1 The outside diameter shall be measured at a distance of at least 300 mm from the end of the pipe.
- 2 In the case of discrepancy, the dimension of pipes shall be measured after conditioning at room temperature ($27^{\circ}\text{C} \pm 2^{\circ}\text{C}$) for 4 h.

Table 3 Mean Outside Diameters and Out-of-roundness
(Clause 7.4)

All dimensions in millimetres.

Sl No.	Nominal Size DN/ØD	Nominal Outside Diameter d_n	Mean Outside Diameter		Maximum Out-of-Roundness (Ovality) (6)
			(dem. Min) (4)	(dem. Max) (5)	
(1)	(2)	(3)	(4)	(5)	(6)
i)	16	16	16.0	16.3	1.2
ii)	20	20	20.0	20.3	1.2
iii)	25	25	25.0	25.3	1.2
iv)	32	32	32.0	32.3	1.3
v)	40	40	40.0	40.4	1.4
vi)	50	50	50.0	50.4	1.4
vii)	63	63	63.0	63.4	1.5
viii)	75	75	75.0	75.5	1.6
ix)	90	90	90.0	90.6	1.8
x)	110	110	110.0	110.7	2.2
xi)	125	125	125.0	125.8	2.5
xii)	140	140	140.0	140.9	2.8
xiii)	160	160	160.0	161.0	3.2
xiv)	180	180	180.0	181.1	3.6
xv)	200	200	200.0	201.2	4.0
xvi)	225	225	225.0	226.4	4.5
xvii)	250	250	250.0	251.5	5.0
xviii)	280	280	280.0	281.7	9.8
xix)	315	315	315.0	316.9	11.1
xx)	355	355	355.0	357.2	12.5
xxi)	400	400	400.0	402.4	14.0
xxii)	450	450	450.0	452.7	15.6
xxiii)	500	500	500.0	503.0	17.5
xxiv)	560	560	560.0	563.4	19.6
xxv)	630	630	630.0	633.8	22.1
xxvi)	710	710	710.0	716.4	—
xxvii)	800	800	800.0	807.2	—
xxviii)	900	900	900.0	908.1	—
xxix)	1 000	1 000	1 000.0	1 009.0	—
xxx)	1 200	1 200	1 200.0	1 210.8	—
xxxi)	1 400	1 400	1 400.0	1 412.6	—
xxxii)	1 600	1 600	1 600.0	1 614.4	—
xxxiii)	1 800	1 800	1 800.0	1 816.2	—
xxxiv)	2 000	2 000	2 000.0	2 018.0	—

NOTE — For coiled pipes and for straight lengths with diameters ≥ 710 mm, the maximum out-of-roundness shall be as agreed to between the manufacturer and the purchaser.

7.4.1.2 Ovality

Ovality shall be measured at 300 mm away from cut end, using a scale having suitable graduations. For coiled pipes and pipes having SDRs ≥ 21 , re-rounding shall be permissible before the measurement of ovality. The ovality shall be measured during extrusion and prior to coiling.

8. PERFORMANCE REQUIREMENTS

8.1 Hydraulic Characteristics

8.1.1 Internal Pressure Creep Rupture Test of Pipe

When subjected to internal pressure creep rupture test in accordance with procedure given in Annex E and test parameters as specified in Table 5, the pipes under test shall show no signs of localized swelling, leakage or weeping and shall not burst during the prescribed test period.

Table 4 Standard Dimension Ratio (SDR) and Corresponding Wall Thicknesses (e) of Pipes
(Clauses 7.4 and E-4.3)

SDR	SDR 41		SDR 33		SDR 26		SDR 21		SDR 17		SDR 13.6		SDR 11		SDR 9		SDR 7.4		SDR 6	
	Nominal Pressure (PN) Bar																			
PE 63	PN 2		PN 2.5		PN 3.2		PN 4		PN 5		PN 6		PN 8		-		-		-	
PE 80	PN 2.5		PN 3.2		PN 4		PN 5		PN 6		PN 8		PN 10		PN 12.5		PN 16		PN 20	
PE 100	PN 3		PN 4		PN 5		PN 6		PN 8		PN 10		PN 12.5		PN 16		PN 20		-	
Nominal OD d _n , mm	e _{Min}		e _{Max}		e _{Min}		e _{Max}		e _{Min}		e _{Max}		e _{Min}		e _{Max}		e _{Min}		e _{Max}	
	mm	mm	mm	mm	mm	mm	mm	mm	mm	mm	mm	mm	mm	mm	mm	mm	mm	mm	mm	mm
16															1.8	2.1	2.2	2.5	2.7	3.1
20													1.9	2.2	2.3	2.6	2.7	3.1	3.4	3.8
25											1.9	2.2	2.3	2.6	2.8	3.2	3.4	3.8	4.2	4.7
32									1.9	2.2	2.4	2.7	2.9	3.3	3.6	4.1	4.4	4.9	5.4	6.0
40							1.9	2.2	2.4	2.7	3.0	3.4	3.7	4.2	4.5	5.1	5.4	6.0	6.7	7.5
50					2.0	2.3	2.4	2.7	3.0	3.4	3.7	4.2	4.6	5.2	5.6	6.3	6.8	7.6	8.4	9.3
63					2.5	2.9	3.0	3.4	3.7	4.2	4.7	5.3	5.8	6.5	7.0	7.8	8.6	9.6	10.5	11.7
75	1.9	2.2	2.3	2.6	2.9	3.3	3.6	4.1	4.5	5.1	5.6	6.3	6.9	7.7	8.4	9.3	10.2	11.3	12.5	13.9
90	2.2	2.5	2.8	3.2	3.5	4.0	4.3	4.8	5.3	5.9	6.7	7.5	8.2	9.1	10.0	11.1	12.2	13.5	15.0	16.6
110	2.7	3.1	3.4	3.8	4.3	4.8	5.3	6.0	6.5	7.3	8.1	9.0	10.0	11.1	12.3	13.6	14.9	16.5	18.4	20.3
125	3.1	3.5	3.8	4.3	4.8	5.4	6.0	6.7	7.4	8.2	9.2	10.2	11.4	12.7	13.9	15.4	16.9	18.7	20.9	23.1
140	3.5	4.0	4.3	4.8	5.4	6.0	6.7	7.5	8.3	9.2	10.3	11.4	12.8	14.2	15.6	17.3	19.0	21.0	23.4	25.8
160	3.9	4.4	4.9	5.5	6.2	6.9	7.7	8.6	9.5	10.6	11.8	13.1	14.6	16.2	17.8	19.7	21.7	24.0	26.7	29.5
180	4.4	4.9	5.5	6.2	7.0	7.8	8.6	9.6	10.6	11.8	13.3	14.7	16.4	18.1	20.0	22.1	24.4	26.9	30.0	33.1
200	4.9	5.5	6.1	6.8	7.7	8.6	9.6	10.7	11.8	13.1	14.7	16.3	18.2	20.1	22.3	24.6	27.1	29.9	33.4	36.8
225	5.5	6.2	6.9	7.7	8.7	9.7	10.8	12.0	13.3	14.7	16.6	18.4	20.5	22.7	25.0	27.6	30.5	33.7	37.5	41.4
250	6.1	6.8	7.6	8.5	9.7	10.8	12.0	13.3	14.7	16.3	18.4	20.3	22.8	25.2	27.8	30.7	33.8	37.3	41.7	46.0
280	6.9	7.7	8.5	9.5	10.8	12.0	13.4	14.8	16.5	18.3	20.6	22.8	25.5	28.2	31.2	34.4	37.9	41.8	46.7	51.5
315	7.7	8.6	9.6	10.7	12.2	13.5	15.0	16.6	18.6	20.6	23.2	25.6	28.7	31.7	35.0	38.6	42.6	47.0	52.5	57.9
355	8.7	9.7	10.8	12.0	13.7	15.2	16.9	18.7	20.9	23.1	26.1	28.8	32.3	35.6	39.5	43.6	48.0	52.9	59.2	65.2
400	9.8	10.9	12.2	13.5	15.4	17.0	19.1	21.1	23.6	26.1	29.5	32.6	36.4	40.1	44.5	49.1	54.1	59.6	66.7	73.5
450	11.0	12.2	13.7	15.2	17.3	19.1	21.5	23.8	26.5	29.3	33.1	36.5	40.9	45.1	50.0	55.1	60.9	67.1	75.0	82.6
500	12.2	13.5	15.2	16.8	19.3	21.3	23.9	26.4	29.5	32.6	36.8	40.6	45.5	50.2	55.6	61.3	67.6	74.5	83.4	91.8
560	13.7	15.2	17.0	18.8	21.6	23.9	26.7	29.5	33.0	36.4	41.2	45.4	50.9	56.1	62.3	68.6	75.7	83.4	93.4	102.8
630	15.4	17.0	19.1	21.1	24.3	26.8	30.0	33.1	37.1	40.9	46.4	51.1	57.3	63.1	70.0	77.1	85.2	93.8	105.0	115.6
710	17.3	19.1	21.6	23.9	27.3	30.1	33.9	37.4	41.8	46.1	52.2	57.5	64.6	71.2	78.9	86.9	96.0	105.7	118.4	130.3
800	19.5	21.6	24.3	26.8	30.8	34.0	38.1	42.0	47.1	51.9	58.9	64.9	72.8	80.2	88.9	97.9	108.2	119.1		
900	22.0	24.3	27.3	30.1	34.7	38.3	42.9	47.3	53.0	58.4	66.2	72.9	81.9	90.2	100.0	110.1	121.7	134.0		
1 000	24.4	26.9	30.3	33.4	38.5	42.5	47.7	52.6	58.9	64.9	73.6	81.1	90.9	100.1	111.2	122.4				
1 200	29.3	32.3	36.4	40.1	46.2	50.9	57.2	63.0	70.6	77.8	88.3	97.2	109.1	120.1						
1 400	34.1	37.6	42.5	46.9	53.9	59.4	66.7	73.5	82.4	90.7	103.0	113.4								
1 600	39.0	43.0	48.5	53.5	61.6	67.9	76.2	83.9	94.2	103.7	117.7	129.6								
1 800	43.9	48.4	54.6	60.2	69.3	76.3	85.8	94.5	105.9	116.6										
2 000	48.8	53.8	60.6	66.8	77.0	84.8	95.3	104.9	117.7	129.6										

NOTES

- 1 Tolerances calculated from (0.1 e_{Min} + 0.1) mm rounded up to the next 0.1 mm.
- 2 All pressure ratings are calculated at 27°C and rounded up to nearest pressure class.
- 3 Considering operational problems, maximum wall thickness of pipes are considered around 130 mm.

Table 5 Hydraulic Characteristic Requirements of Pipes
(Clauses 8.1.1 and E-4.3)

Sl No.	Test Temp °C	Test Duration h	Induced Hoop Stress MPa		
			PE 63 (4)	PE 80 (5)	PE 100 (6)
i)	27	100	6.9	8.6	10.7
ii)	80	48	3.8	4.9	5.7
iii)	80	165	3.5	4.5	5.4
iv)	80	1000	3.2	4.0	5.0

8.1.2 Internal Pressure Creep Rupture Test of Pipe Joints

The pipe joints shall also be tested for the hydraulic characteristic requirement by subjecting the butt fusion joint or electro fusion joint of a pipe to internal pressure creep rupture test at 80°C for 48 h as per Table 5 and in accordance with the method given in Annex E. The pipe joints under test shall show no signs of localized swelling, leakage or weeping and shall not burst during the prescribed test period.

8.2 Longitudinal Reversion Test

When tested in accordance with the method given in Annex F, the value of the longitudinal reversion shall not be greater than 3 percent.

8.3 Carbon Black Content and Dispersion

When tested from a composite sample of minimum three pipes, in accordance with NS 97 the carbon black content shall be within 2.5 ± 0.5 percent, and the dispersion of carbon black shall be satisfactory.

8.4 Melt Flow Rate

When tested from a composite sample of minimum three pipes as per NS 97 at 190° C with nominal load of 5 kgf, MFR shall not deviate from the MFR of the resin by more than 30 percent.

8.5 Oxidation Induction Time

The minimum oxidation induction time of the pipe when tested in accordance with the method given in Annex B shall be not less than 20 min.

8.6 Overall Migration

When tested from a sample of minimum 3 pipes as per NS..., the overall migration of constituents shall be within the limits stipulated in NS....

8.7 Density

When tested from a composite sample of minimum of 3 pipes as per NS 110, the base density of the pipe shall be between 930 to 965 kg/m³.

8.8 Tensile Strength for Butt-fusion

When tested according to Annex G, the test specimens prepared by punching /machining from pipe butt fusion sample preferably 110 mm Dia/SDR 11 shall show ductile failure. If the sample shows brittle fail the test may be considered as a failure.

NOTE — If 110 mm/SDR 11 pipes are not being manufactured, test shall be carried out on the nearest, preferably higher size/ SDR ratio being manufactured.

8.9 Elongation at Break

When tested according to Annex H, the test specimens punched/machined from pipe samples, shall meet requirement as per Table 6.

Table 6 Elongation at Break Requirements of Pipes
(Clause 8.9)

S. No. (1)	Characteristics (2)	Requirements (3)	Test Parameters		Test Method Ref to (6)
			Parameter (4)	Value (5)	
i	Elongation at break for $e \leq 5$ mm	≥ 350 Percent	Test piece shape Test speed	Type 2 100 mm/min	Annex H
ii	Elongation at break for 5 mm < $e \leq 12$ mm	≥ 350 Percent	Test piece shape Test speed	Type 1 ¹⁾ 50 mm/min	Annex H
iii	Elongation at break for $e > 12$ mm	≥ 350 Percent	Test piece shape Test speed	Type 1 ¹⁾ 25 mm/min	Annex H
				OR	
			Test piece shape Test speed	Type 3 ¹⁾ 10 mm/min	

¹⁾ Where practical, machined type 2 test pieces may be used for pipe wall thickness ≤ 25 mm. The test may be terminated when the requirement is met, without continuing until the rupture of the test piece.

8.10 Slow Crack Growth Rate

When subjected to test parameters as given below and tested in accordance with the procedure given in Annex E, the notched test specimens prepared from pipe size of preferably 110 mm and SDR 11 in accordance with Annex J shall show no signs of localized swelling, leakage or weeping and shall not burst during the prescribed test period.

Test Temperature °C	Test Duration H	Internal Test Pressure, MPa		
		PE 63	PE 80	PE 100
80±1	500 h	0.64	0.8	0.92

NOTE — If 110 mm / SDR 11 pipes are not being manufactured, test shall be carried out on the nearest, preferably higher size/ SDR ratio being manufactured.

9. SAMPLING, FREQUENCY OF TESTS AND CRITERIA FOR CONFORMITY

9.1 Type Tests

9.1.1 Type tests are intended to prove the suitability and performance of a new composition, a new technique or a new size of a pipe. Such tests, therefore, need be applied only when a change is made in polymer composition or method of manufacture, or when a new size of pipe is to be introduced. Even if no change is envisaged, type test shall be done at least once in two years on each pressure rating and grade of pipe of the highest size manufactured during the period.

9.1.2 Three samples of the same grade, same size and same SDR selected at random shall be tested for compliance with the requirements of the type tests as given in Table 7.

- 9.1.3** If all the samples pass the requirements of the type test, the type of the pipe under consideration shall be considered eligible for type approval.
- 9.1.4** In case of any of the samples fails in the type test, the testing authority, at its discretion, may call for fresh samples not exceeding the original number and subject them to the type test again. If in repeat test, no single failure occurs, the type of pipe under consideration shall be considered eligible for type approval. If any of the samples fails in the repeat tests, the type of pipe shall not be approved. The manufacturer or the supplier may be asked to improve the design and resubmit the product for type approval.
- 9.1.5** At the end of the validity period (normally one year for internal pressure creep rupture test at 27°C for 100 h and internal pressure creep rupture test for joints at 80°C for 48 h and two years for all other type tests) or earlier as may be necessary, the testing authority may call for fresh samples for type-test for the purpose of type approval.

Table 7 Type Tests

(Clause 9.1.2)

Sl No. (1)	Description of Test (2)	Sample Requirement	
		Size (3)	Clause (4)
i)	Tensile strength for butt-fusion	3	8.8
ii)	Overall migration	3	8.6
iii)	Internal pressure creep rupture test (hydrostatic resistance test) at 27°C for 100 h	3	8.1.1
iv)	Internal pressure creep rupture test (hydrostatic resistance test) at 80°C for 165 h	3	8.1.1
v)	Internal pressure creep rupture test (hydrostatic resistance test) at 80°C for 1 000 h test	3	8.1.1
vi)	Slow crack growth rate test	3	8.10
vii)	Internal Pressure Creep Rupture Test (Hydrostatic Creep Rupture Test) for Joints at 80°C for 48 h	3	8.1.2

9.2 Acceptance Test

9.2.1 Acceptance tests are carried out on sample selected from a lot for the purpose of acceptance of the lot.

9.2.2 Lot

All pipes of the same grade, same size, same SDR and also manufactured essentially under similar conditions of manufacture shall constitute a lot. For ascertaining conformity of the lot to the requirements of this standard, samples for acceptance tests (see Table 8) shall be selected and prepared after conditioning at $27 \pm 2^\circ\text{C}$ and tested for compliance as per Table 8.

Table 8 Acceptance Tests
(Clause 9.2.2)

Sl No.	Description of Test	Sample Size	Requirement Clause
i)	Visual appearance and dimensions	Table 9	7.1 and 7.4
ii)	Melt flow rate	Table 10	8.4
iii)	Density	Table 10	8.7
iv)	Reversion test	Table 10	8.2
v)	Elongation at break	Table 10	8.9
vi)	Carbon black content	Table 10	8.3
vii)	Carbon black dispersion	Table 10	8.3
viii)	Oxidation Induction	Table 10	8.5
ix)	Internal pressure creep rupture test (hydrostatic resistance test) at 80°C for 48 h	Table 10	8.1.1

9.2.3 Conformity to Dimensional and Visual Characteristics

9.2.3.1 The number of test samples shall be in accordance with Table 9.

9.2.3.2 These pipes shall be selected at random from the lot and in order to ensure the randomness of selection, a random number table shall be used. For guidance and use of random number tables, NS 145 may be referred. For the above purpose, each length of the coil of a given size, grade and SDR shall be considered as one pipe. In the absence of a random number table, the following procedure may be adopted.

Starting from any pipe in the lot, count them as 1, 2, 3, 4 etc, up to r and so on where r is the integral part of N/n , N being the number of pipes in the lot and n is the number of pipes in the samples. Every r^{th} pipe so counted shall be drawn so as to constitute the required sample size.

9.2.3.3 The number of pipes given for the first sample in col 4 of Table 9 shall be examined for visual and dimensional requirements as given in 7.1 and 7.4 respectively. A pipe failing to satisfy any of these requirements shall be considered as defective. The lot shall be deemed to have satisfied these requirements, if the number of defectives found in the first sample are less than or equal to the corresponding acceptance number given in col 6 of Table 9. The lot shall be deemed not to have met these requirements if the number of defectives found in the first sample is greater than or equal to the corresponding rejection numbers given in col 7 of Table 9. If, however, the number of defectives found in the first sample lies between the corresponding acceptance and rejection numbers given in col 6 and 7 of Table 9, the second sample of the size given in col 4 of Table 9 shall be taken and examined for these requirements. The lot shall be considered to have satisfied these, requirements, if the number of defectives found in the cumulative sample is less than or equal to the corresponding acceptance number given in col 6 of Table 9 otherwise not. In case, the sample size is equal to or less than the lot size, 100 percent inspection shall be done for these tests and all the samples from the lot which pass these tests shall be tested for other acceptance tests.

9.2.4 Conformity to Acceptance Tests Other Than Dimensional and Visual Characteristics

The lot having satisfied dimensional and visual requirements shall be tested for other acceptance tests as given in Table 8. The number of test samples selected from the lot for subjecting to these tests shall be in accordance with Table 10. For the above purpose, each length of the coil of a given size, grade and SDR shall be considered as one pipe. The lot shall be considered to have met the requirements of these tests, if none of samples tested fails.

Table 9 Scale of Sampling for Dimensional Requirements
(Clauses 9.2.3.1 and 9.2.3.3)

Sl No.	No. of Pipes in the Lot	Sample No.	Sample Size	Cumulative Sample Size	Acceptance No.	Rejection No.
i)	Up to 150	First	13	13	0	2
		Second	13	26	1	2
ii)	151 to 280	First	20	20	0	3
		Second	20	40	3	4
iii)	281 to 500	First	32	32	1	4
		Second	32	64	4	5
iv)	501 to 1200	First	50	50	2	5
		Second	50	100	6	7
v)	1201 to 3200	First	80	80	3	7
		Second	80	160	8	9
vi)	3201 to 10000	First	125	125	5	9
		Second	125	250	12	13
vii)	10001 to 35000	First	200	200	7	11
		Second	200	400	18	19

Table 10 Scale of Sampling for Acceptance Tests Other Than Dimensional Requirements
(Clauses 9.2.2 and 9.2.4)

Sl No.	No. of Pipes in the Lot	Sample Size
a) For Pipe Sizes Upto 500 mm		
i)	Up to 150	3
ii)	151 to 1200	5
iii)	1201 to 35000	8
b) For Pipe Sizes Above 500 mm		
iv)	Up to 500	3
v)	501 to 1 200	5
vi)	1201 to 35000	5

10. MARKING

10.1 Each straight length/coil of pipe shall be clearly and indelibly marked in white/yellow colour using ink/ paint or inkjet print or hot embossed on white base, at every 1 m throughout the length of pipe/coil with the information given in 10.1.1.

10.1.1 The marking on the pipe shall carry the following minimum information:

- Manufacturer's name/trade-mark;
- Material designation, PE... (see 6.1);
- Pressure rating;
- Standard dimension ratio (SDR);
- Nominal Size; and
- Lot Number/Batch Number, containing information of date of manufacture shall include the details of production in the following manner

Year	Month	Day	Machine No.	Shift
Xxxx	Xx	Xx	xx	xx

10.2 NS Certification Marking

Each pipe/coil may also be marked with the Standard Mark.

10.2.1 The use of the Standard Mark is governed by the provisions of the Nepal Standards (Certification Mark) Act, 2037 and the Rules and Regulations made there under. The details of conditions under which a license for the use of the Standard Mark may be granted to manufacturers or producers may be obtained from the Nepal Bureau of Standards and Metrology.

ANNEX A

(Clause 3.17)

THE RELATIONSHIP BETWEEN MINIMUM REQUIRED STRENGTH, NOMINAL PRESSURE AND STANDARD DIMENSION RATIO

A-1 The relation between nominal pressure (at 27°C) (PN), design stress at 20°C (σ), and the standard dimension ratio (SDR) is given by the following equation:

$$PN = \frac{20\sigma}{SDR - 1} \times f_T$$

Where, $\sigma = MRS/C$

PN = nominal pressure at 27°C, in bar

MRS = minimum required strength of the material class (see Table 1),

C = overall service design co-efficient = 1.25,

f_T = pressure reduction co-efficient = 0.85 for 27°C (from Fig. 1), and

SDR = standard dimension ratio.

The Nominal Pressure (PN) for various material class and different SDRs has been calculated using the above equation and is given in the informal Table below

However, if a higher value for C is required, the PN values will have to be recalculated using the above equation considering the calculated design stress, σ for each class. A higher value for C can also be obtained by choosing a higher PN class.

Sl. No.	SDR	Standard Dimension Ratio (SDR) Used in Wall Thickness Chart (Table 5) at 27°C		
Nominal Pressure for Material Class in Bar				
(1)	(2)	PE 63 (3)	PE 80 (4)	PE 100 (5)
i)	41	2.0	2.5	3.0
ii)	33	2.5	3.2	4.0
iii)	26	3.2	4.0	5.0
iv)	21	4.0	5.0	6.0
v)	17	5.0	6.0	8.0
vi)	13.6	6.0	8.0	10.0
vii)	11	8.0	10.0	12.5
viii)	9	—	12.5	16.0
ix)	7.4	—	16.0	20.0
x)	6	—	20.0	—

ANNEX B

[Table 2 SI No. (iii)]

METHOD FOR DETERMINATION OF OXIDATION INDUCTION TIME (THERMAL STABILITY)

B-1 APPARATUS AND EQUIPMENT

B-1.1 A differential thermal analyzer (DTA)/differential scanning calorimeter (DSC), calibrated using pure indium and pure tin to give values which lie within $156.6 \pm 0.5^\circ\text{C}$ and $231.9 \pm 0.5^\circ\text{C}$ respectively. The test cell shall allow the cell to be purged within 1 min by use of successive gases at the specified flow rate.

B-1.2 Aluminium pans, large enough to accommodate a test piece in solid or molten form.

B-2 TEST PIECES

A sample from the pipe shall be taken by use of a core drill directed radially through the pipe wall. The diameter of the core shall be just less than the inner diameter of the sample pan of the thermal analyzer, and care should be taken not to overheat the sample during the coring operation. Using a scalpel, cut the test pieces that weigh 15 ± 0.5 mg in the form of discs from the core sample, selecting the inner surface.

Outer surface and mid-wall as the minimum sample points which are to be tested individually.

B-3 PROCEDURE

Establish a nitrogen flow of $50\text{ cm}^3/\text{min} \pm 10$ percent through the differential thermal analyzer or differential scanning calorimeter cell. Check that when a switchover to oxygen is made the gas flow will continue at the rate of $50\text{ cm}^3/\text{min} \pm 10$ percent and then revert to a nitrogen flow of $50\text{ cm}^3/\text{min} \pm 10$ percent.

Place a $15\text{ mg} \pm 0.5\text{ mg}$ cylindrical polyethylene specimen in an open aluminium pan an empty aluminium reference pan into the cell. Set the instrument to run isothermally at $200^\circ\text{C} \pm 0.1^\circ\text{C}$ raising the temperature at a rate of $20^\circ\text{C}/\text{min}$ and allowing the temperature to stabilize. Make any corrections to the heater voltage to bring the specimen temperature to $200^\circ\text{C} \pm 0.1^\circ\text{C}$. Start to record the thermo graph.

When stable conditions exist under the nitrogen flow, which should be the case after 5 min switch over to oxygen and mark this point on the thermo graph. The cell should be purged within 1 min of atmosphere changeover. Continue to run the thermo graph until the oxidation exotherm has occurred, and has reached its maximum.

B-4 INTERPRETATION OF RESULTS

The thermal stability of the specimen is the time taken in minutes from the introduction of oxygen to the intercept of the extended baseline and the tangent drawn to the exotherm at the point of maximum slope.

ANNEX C

[Table 2 SI No. (iv)]

METHOD FOR DETERMINATION OF VOLATILE CONTENT IN POLYETHYLENE PIPING MATERIALS AND COMPONENTS

C-1 PRINCIPLE

The method consists of determining the loss of mass of a test piece which has been put in a drying oven at a given temperature. The method is used for determining the content of material which volatiles at 105°C in polyethylene (PE) piping materials. This method is also applicable to moulding and extrusion materials. It can be also applicable to components in PE piping systems.

C-2 APPARATUS

C-2.1 Drying Oven or Equivalent Device, capable of maintaining the temperature at $(105 \pm 2)^\circ\text{C}$ at the position for the cup(s) (see C-3.2 and C-5.4).

C-2.2 A Cylindrical Glass Weighing Cup, with a diameter of 35 mm capable of containing a test piece (see C-4.1), a minimum volume of 50 ml and a corresponding lid.

C-2.3 A Desiccators

C-2.4 An Analytical Balance or Equivalent, capable of weighing to the nearest 0.1 mg.

C-3 TEST PIECE

C-3.1 Each test piece shall comprise an approximately 25 g portion of a sample representative of the material before molding or extrusion, as applicable, or cut in accordance with the referring standard from a cross section of a pipe or fitting.

NOTE — If test sample utilize different sampling weights or are taken from different sources, for example raw material granulate or finished product, then there may be a difference in test results obtained. This may depend on, for example, the surface area/mass ratio or the maximum thickness of material. To demonstrate correlation with results for granulate sample determined in accordance with this method, the preparation of samples from finished products may have to be modified.

C-3.2 The number of test pieces shall be as specified in Table 2.

C-4 PROCEDURE

C-4.1 Clean and dry a weighing cup and its lid until constant weight is achieved and store them in the desiccators for at least 0.5 h at room temperature.

C-4.2 Take the weighing cup and its lid out of the desiccator and determine their combined mass, m_0 to the nearest 0.1 mg.

C-4.3 Fill the cup with about 25 g portion of the sample and determine the mass, m_1 , of the cup, lid and the test portion to the nearest 0.1 mg.

C-4.4 Put the weighing cup in the drying oven zone which is kept at $(105 \pm 2)^\circ\text{C}$ (see C-3.1).

C-4.5 After a period of 65 ± 5 min, take the weighing cup out of the drying oven and put the cup in the desiccator for at least 1h at room temperature.

C-4.6 Cover the cup with the lid. Weigh the cup, lid and residual material to the nearest 0.1 mg, as mass m_2 .

C-5 CALCULATION

Calculate the volatile material content, m_v , of the test portion using the following equation:

$$m_v = \frac{m_1 - m_2}{m_1 - m_0} \times 10^6$$

Where,

m_v = volatile material content in milligrams per kilogram (mg/kg) at $(105 \pm 2)^\circ\text{C}$;

m_0 = mass in grams of the empty weighing cup and its lid;

m_1 = mass in grams of the weighing cup and its lid plus the test portion; and

m_2 = mass in grams of the weighing cup and its lid plus the residual material after 1 h at $(105 \pm 2)^\circ\text{C}$.

ANNEX D

[Table 2 SI No. (v)]

METHOD FOR DETERMINATION OF WATER CONTENT IN POLYETHYLENE PIPING MATERIALS AND COMPONENTS

D-1 PRINCIPLE

This method of determining water content of plastics

is an extraction method, in which a test portion is extracted with anhydrous methanol and the extracted water determined by titration using the Karl Fischer method. It can be used for all plastics and is applicable

to granules having a maximum size of 4 mm × 4 mm ×

3 mm. The method do not test for water absorption

(kinetics and equilibrium) of plastics. It is suitable for the determination of water content as low as of 0.1 percent or above.

D-2 REAGENT

During the analysis, reagents of recognized analytical grade should only be used.

- a) Methanol, anhydrous, having water content less than 0.1 percent by mass.
- b) Karl Fischer Reagent, with an equivalent factor of approximately 3 mg/ml to 5 mg/ml

of water, if the reagent is prepared; check its equivalent factor.

D-3 APPARATUS

Ordinary laboratory apparatus and the following:

- a) Glass Flasks, 250 ml capacity provided with ground-glass or rubber stoppers.
- b) Conical Titration Flasks, 150 ml capacity, with standard ground necks and provided with ground-glass stoppers.
- c) Reflux Condensers, with ground neck capable of being fitted on to the flasks [D-3 (b)] and on to the tubes [D-3 (d)].

- d) Water Absorption Tubes with ground joints, containing calcium chloride or other drying agent.
- e) Electrical or Hot-air Heaters, for the flasks [D-3 (b)].
- f) Pipettes, 50 ml capacity (automatic filling Pipettes are acceptable).
- g) Woulfe Bottles, with two tubes.
- h) Curved or U-shaped Water Absorption Tubes, filled with calcium chloride.
- j) Rubber Pipette Filler
- k) Pipette, 10 ml capacity
- m) Desiccator, containing calcium chloride
- n) Analytical Balance, accurate to 0.2 mg
- p) Karl Fischer Apparatus, for determining water content.

D-4 PREPARATION OF TEST SAMPLE

D-4.1 Granules

Take a representative sample of approximately 100 g. Put the sample into a pre-dried glass flask

[see D-3 (a)] and immediately close it with a stopper.

NOTE — It is desirable pre-dry the container in an oven, and then cools it over a suitable water absorbent, for instance silica gel.

D-4.2 Finished Articles

Cut or saw the sample into pieces of approximate size, that is, having a maximum size of 4 mm × 4 mm × 3 mm.

D-5 PROCEDURE**D-5.1 Precautions**

Due to the low quantities of water measured, maximum care shall be taken exercised at all times to avoid contaminating the sample with water from the sample container, the atmosphere or transfer equipment. Hygroscopic resin samples shall be shall be protected from the atmosphere.

D-5.2 Preparation of Test Portions

Conduct the test on two test portions from the same sample. Use test portions containing 10 mg to 20 mg of water based on the estimated water content of the sample.

D-5.3 Determination

- a) Carefully dry the apparatus.
- b) Weigh each test portion the nearest 1 mg into a conical titration flask [D-3 (b)] fitted with a ground-glass stopper. Pipette 50 ml [D-3 (f)] of anhydrous methanol [D-2 (a)] into the conical flask containing the test portion. At the same time, add 50 ml of anhydrous methanol to another conical flask for a blank test. Stopper the flask. Keep the stoppered flasks in the desiccator [D-3 (m)] pending continuation of the test.
- c) Unstopper the flask and quickly attach them to reflux condensers [D-3 (c)] fitted with calcium chloride tube [D-3 (d)]. Reflux the contents of the conical flasks for 3h, then leave them for 45 min to cool to room temperature.

Separate the flask from the condenser, quickly stopper them and place them in the desiccator.

- d) Use the Karl Fischer apparatus [D-3 (p)] to titrate the contents of each flask with Karl Fischer reagent [D-2 (b)].

D-6 EXPRESSION OF RESULTS

The water content w_1 expressed as a percentage by mass, for each of the two determinations is determined by the following formula:

$$w = \frac{(V_1 - V_2)T}{m \times 100}$$

where

V_1 is the volume, expressed in millilitres, of Karl Fischer reagent used for the determination;

V_2 is the volume, expressed in millilitres, of Karl Fischer reagent used for the blank test;

T is the water equivalent, expressed in the grams of water per millilitre of reagent, of Karl Fischer reagent, and

m is the mass, in gram of the test portion.

The two values for the water content shall not differ by more than 10 percent relative or 0.02 percent absolute, whichever is the greater. If the difference is greater, repeat the measurement until acceptable consecutive values are obtained and discard all unacceptable results.

The result is expressed as the average of these two determinations, rounded to the nearest 0.01 percent by mass.

ANNEX E
(Clauses 8.1.1, 8.1.2 and 8.10)
INTERNAL PRESSURE CREEP RUPTURE TEST

E-1 GENERAL

The test shall be carried out not earlier than 24 h after the pipes have been manufactured.

E-2 TEST SPECIMENS

A sample of pipe having free length between the end fittings equal to ten times the outside diameter but not less than 250 mm and not greater than 750 mm shall be taken for testing from each pipe to be tested.

E-3 APPRATUS

Equipment permitting the application of a controlled internal hydraulic pressure to the specimen which are immersed in a thermostatically controlled water-bath.

E-4 PROCEDURE

E-4.1 The pipes shall be fitted with the locking plugs at both ends in such a way that the axial force coming from the internal pressure are transmitted to the pipe. The pipe shall remain free to move in longitudinal direction.

E-4.2 Through a closable operating in one of the locking plugs, the pipe shall be filled with water at ambient temperature. It shall be put in a water bath at the applicable test temperature (permissible deviation of $\pm 1^\circ\text{C}$) and kept in the bath for minimum 1 h to adjust the temperature.

E-4.3 The pressure in the pipe shall then be increased to the test pressure (p) gradually and without shock, preferably within 10 to 30 s in the bath whose temperature has been adjusted in accordance with E-4.2. The pressure with a permissible deviation of ± 2.5 percent shall be maintained for the applicable test duration.

The test pressure (p) shall be calculated as follows from the minimum dimension given in Table 4 as the case may be and corresponding induced stress value given in Table 5.

$$p = \frac{2\sigma_i s}{d - s}$$

Where

- p = test pressure, in MPa;
- S = minimum wall thickness, in mm;
- σ_i = induced stress, in MPa; and
- d = outside diameter of pipe, in mm.

E-5 The sample shall not show sign of localized swelling or leakage and shall not burst during the prescribed test duration. The test showing failure within a distance equivalent to the length of end cap from the end shall be disregarded and the test be repeated.

ANNEX F
(Clause 8.2)

LONGITUDINAL REVERSION TEST

F-1 APPARATUS

F-1.1 Air Oven — Thermostatically controlled at 110±2°C and is capable of re-establishing this temperature within 15 minutes after the introduction of test specimen in the oven.

F-1.2 Thermometer — Graduated to 0.5°C.

F-1.3 Test Specimens — Either 3 complete sections of pipe, approximately 200 mm long shall be taken as test pieces, or where the pipe diameter is greater than 200 mm, pieces of pipe about 200 mm axial length and with an approximate circumferential arc length of 200mm shall be prepared by cutting. In such cases, the entire circumference of approximately 200 mm long section of pipe shall be divided into pieces measuring approximately 200 mm square. The direction of the pipe axis shall be marked on the pieces. All pieces are required to be tested. A mark shall be scribed on the external surface approximately 50 mm for each end of the test pieces in the axial direction of pipe,(in the case of complete section of pipe, the mark shall be scribed around the whole circumference) . The distance between the marks, l_0 (reference length), shall be approximately 100 mm and shall be measured to the nearest 0.25 mm at ambient temperature.

F-2 PROCEDURE

F-2.1 Place the test pieces concave side up on a glass plate previously dusted with talcum, to ensure that changes in length take unimpeded. The pieces shall not touch each other.

F-2.2 Set the oven temperature at 110 ± 2°C. The glass plate with the test pieces shall then be placed in the oven heated to test temperature and capable of maintaining continuous forced air circulation. The test pieces shall be kept in the oven at the temperature and for the periods specified below:

Wall Thickness, e mm	Test Temperature °C	Period of Stressing min
Up to 8	110±2	60±1
Over 8 and up to 16	110±2	120±2
Over 16	110±2	240±5

F-2.3 Remove the test pieces from the oven and allow to cool in air, without being moved, at the ambient temperature. Measure the minimum distance between the two marks.

F-3 EXPRESSION OF RESULTS

F-3.1 For each test pieces calculate the longitudinal reversion, T, as a percentage, as follows:

$$T = \frac{l_0 - l_1}{l_0} \times 100$$

Where

l_0 and l_1 are the distance (reference length) in mm before and after the test.

F-3.2 The average value (arithmetic mean) of all the test pieces shall be obtained and reported.

ANNEX G

(Clause 8.8)

DETERMINATION OF FAILURE MODE OF TEST PIECES FROM A BUTT-FUSED JOINT

G-1 PRINCIPLE OF THE METHOD

A test piece machined from a butt-fused PE pipe joint to give a waisted section is subjected to a tensile stress at constant speed. When loading the test piece in a tensile-testing machine, the stress is concentrated through the jointed region and ultimate failure is in the vicinity of the joint. The failure mode is used as criteria for the evaluation of the butt-fused joint. The test is carried out at a temperature of $27 \pm 2^\circ\text{C}$.

G-2 APPARATUS

- a) Room, which can be controlled at a temperature of $27 \pm 2^\circ\text{C}$.
- b) Tensile-testing machine, capable of sustaining between its clamping jaws a constant speed of 5 ± 1 mm/min, and equipped with means for recording the consequent applied force and a device to detect test piece failure.
- c) Clamping device, equipped with bars fitting into traction holes machined in the test piece.
- d) Measuring devices, capable of determining the width and thickness of the test piece to within 0.05 mm.
- e) Template with the geometry of the test piece (see Fig. 5 and Fig. 6), to mark the shape of the test piece to be machined.

G-3 TEST PIECES

G-3.1 Preparation

G-3.1.1 General

The butt-fused PE pipe joints shall be prepared in accordance with the manufacturer's instructions or the instructions specified in the IS 7634 (Part 2).

For each test piece required, a strip shall be machined out along the longitudinal direction of the pipe, across the joint. The strip shall be further machined to prepare a test piece with dimensions conforming to following using a template to ensure that the joint interface will be aligned with the cross-section of the centre of the waist of the test piece of type A or type B, as applicable:

- a) Table 11 and Fig. 2 for pipes with wall thickness $e < 25$ mm (Type A);
- b) Table 11 and Fig. 3 for pipes with wall thickness $e \geq 25$ mm (Type B);

The fusion beads may be removed.

G-3.1.2 Type A Test Piece

The dimension and shape of the Type A test piece shall conform to Fig. 2 and Table 11.

The "waist" of the test piece shall be formed by drilling or machining holes with their centres 35 mm

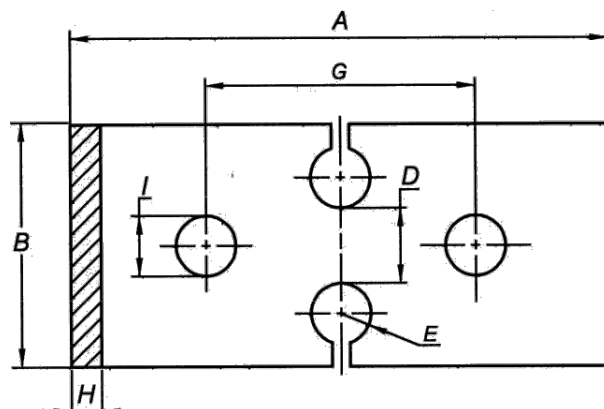

FIG. 2 MACHINED TYPE A TENSILE TEST PIECE
(FOR $E < 25$ mm)

or 45 mm apart, as applicable, so that the centre lines of the holes lie in the same plane as the joint interface, and then cutting towards the holes from the corresponding edge of the strip. The faces of the test piece waist shall be smooth. The finish of the remaining edges is not critical.

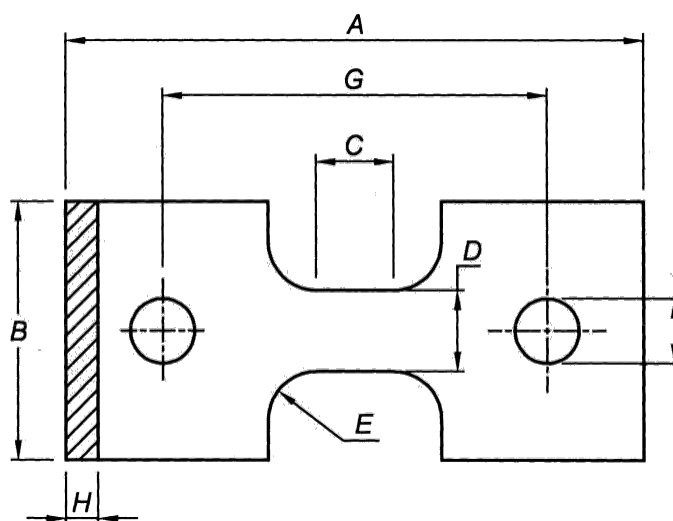

FIG. 3 MACHINE TYPE B TENSILE TEST PIECE (FOR $E \geq 25$ mm)

Table 11 Dimensions of Type A and B Test Pieces
(Clause G-3.1.2)

All dimensions in millimetres.

Sl No.	Symbol	Description	Dimension of Type A Test Piece		Dimensions of Type B Test Piece
			$d_n \leq 160$ mm	$d_n > 160$ mm	
(1)	(2)	(3)	(4)	(5)	(6)
i)	A	Overall length, Min	180	180	250
ii)	B	Width at ends	60 ± 3	80 ± 3	100 ± 3
iii)	C	Length of narrow parallel-sided portion	Not Applicable	Not Applicable	25 ± 1
iv)	D	Width of narrow portion	25 ± 1	25 ± 1	25 ± 1
v)	E	Radius	5 ± 0.5	10 ± 0.5	25 ± 0.5
vi)	G	Initial distance between grip	90 ± 5	90 ± 5	165 ± 5
vii)	H	Thickness	Full wall thickness	Full wall thickness	Full wall thickness
viii)	I	Diameter of traction holes	20 ± 5	20 ± 5	30 ± 5

G-3.1.3 Type B Test Piece

The dimension and shape of the Type B test piece shall conform to Fig. 3 and Table 11.

G-3.2 Number of Test Pieces

The number of test pieces shall depend upon the nominal outside diameter d_n of the pipe as given in Table 12.

Table 12 Number of Test Pieces
(Clause G-3.2)

Sl No.	Nominal Outside Diameter, d_n mm	Number of Test Pieces
i)	$90 \leq d_n < 110$	2
ii)	$110 \leq d_n < 180$	4
iii)	$180 \leq d_n < 315$	6
iv)	$d_n \geq 315$	7

One test piece shall be taken at the position of maximum misalignment. The other test pieces shall be taken uniformly around the circumference of the joint.

G-4 CONDITIONING

Immediately prior to testing in accordance with G-5, condition each test piece in air for a minimum of 6 h at a temperature of $27 \pm 2^\circ\text{C}$, starting the period of conditioning at a time such that testing will not be carried out less than 24 h after the butt fusion of the joint.

G-5 PROCEDURE

- a) Measure the thickness of the test piece as the thickness of the pipe wall and the width of the test piece as the distance between the two holes drilled at the joint (D) for test pieces of type A (see Table 11 and Fig. 2) or as the width of the narrow portion (D) for test pieces of type B (see Table 11 and Fig. 3).
- b) Place the test piece in the clamping device of the tensile-testing machine, so that the direction of the force applied to the test piece is perpendicular to the butt-fusion joint.
- c) Apply tension to the test piece with a cross-head speed of 5 ± 1 mm/min.
- d) Record the force applied during extension until complete failure of the test piece.
- e) Record the type of failure as ductile or brittle. Only failures at the butt-fusion joint shall be taken into account.

G-6 EXPRESSION OF RESULTS

The sample shall not show brittle failure during the prescribed test. The results of all the test pieces shall be obtained and reported.

ANNEX H

(Clause 8.9 and Table 6)

DETERMINATION OF ELONGATION AT BREAK

H-1 APPARATUS

H-1.1 Tensile-testing machine meeting the specifications given in H-1.2 to H-1.4, as follows:

H-1.2 Grips, for holding the test piece and attached to the machine so that the major axis of the test piece coincides with the direction of pull through the centre line of the assembly. This can be achieved, for example, by using centring pins in the grips.

The test piece shall be held such that slip relative to the grips is prevented as far as possible and this shall be effected with the type of grip that maintains or increases pressure on the test piece as the force applied to the test piece increases.

The clamping system shall not cause premature fracture at the grips.

H-1.3 Load indicator, incorporating a mechanism capable of showing the total tensile load carried by the test piece when held by the grips. The mechanism shall be essentially free from inertia lag at the specified rate of testing, and shall indicate the load with an accuracy of within 1 percent of the actual value.

H-1.4 Extensometer, suitable for determining the gauge length of the test piece at any moment during the test.

The instrument shall be essentially free from inertia lag at the specified test speeds and shall be capable of measuring deformation to an accuracy of within 1 percent. Where a mechanical extensometer is used, this shall be fixed to the test piece in such a way that the test piece undergoes the minimum damage and distortion and no slip occurs between it and the extensometer.

The measurement of elongation of the test piece on the basis of the movement of the grips lacks accuracy and shall be avoided whenever possible.

NOTE — It is desirable, but not essential, for this instrument to record this length, or any variation in it, automatically as a function of the stress in the test piece.

H-1.5 Micrometer or equivalent, capable of reading to 0.01 mm or less and suitable for measuring the thickness and width of the test piece.

H-1.6 Cutting die, conforming to the relevant profile in this standard, as applicable.

H-1.7 Milling machine and cutter, capable of producing the test piece specified in this standard, as applicable.

H-2 TEST PIECES

H-2.1 Nature of Test Pieces

H-2.1.1 General

Where the thickness of the pipe is less than or equal to 12 mm, the test pieces shall be cut using a die or obtained by machining. Where the thickness of the pipes is greater than 12 mm the test pieces shall be machined.

H-2.1.2 Dimensions of Test Pieces

Test pieces shall be either of Type 1, the shape and dimensions of which are given in Fig. 4 and Table 13, Type 2, the shape and dimensions of which are given in Fig. 5 and Table 14 or Type 3, the shape and dimensions of which are given in Fig. 6 and Table 15. The choice of test piece is dependent on the wall thickness of the pipe from which it is taken (see H-2).

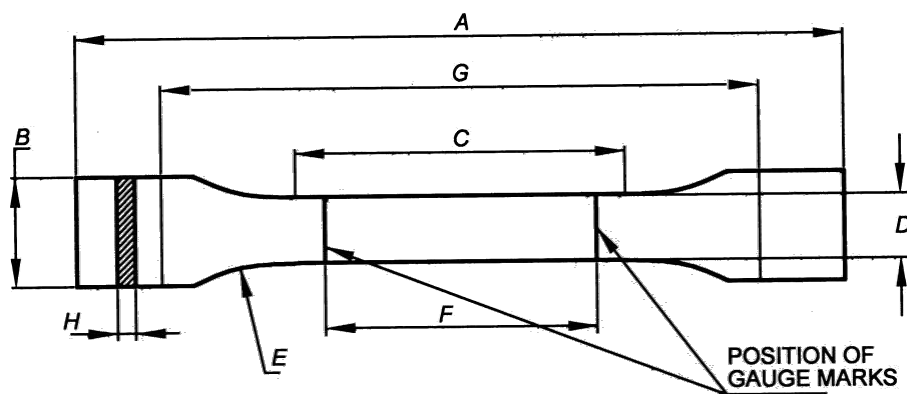

FIG. 4 TYPE 1 TEST PIECE

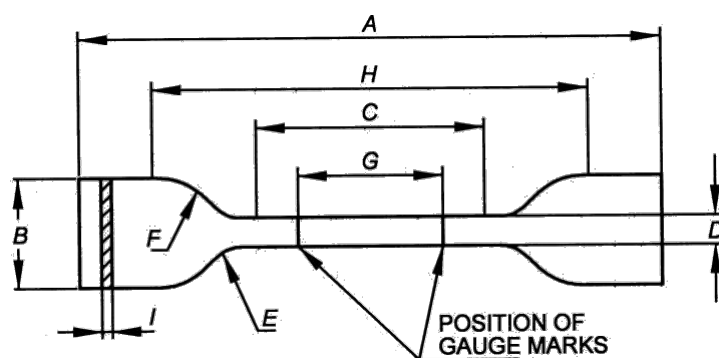

FIG. 5 TYPE 2 TEST PIECE

Table 13 Dimension of Type 1 Test Pieces
(Clause H-2.1.2)

SI Symbol No.	(1)	(2)	Description (3)	Dimension Mm (4)
i)	A		Overall length, Min.	150
ii)	B		Width of ends	20 ± 0.2
iii)	C		Length of narrow, parallel-sided portion	60 ± 0.5
iv)	D		Width of narrow, parallel-sided portion	10 ± 0.2
v)	E		Radius	60
vi)	F		Gauge length	50 ± 0.5
vii)	G		Initial distance between grips	115 ± 0.5
viii)	H		Thickness	That of the Pipe

Table 14 Dimension of Type 2 Test Pieces
(Clause H-2.1.2)

SI Symbol No.	(1)	(2)	Description (3)	Dimension Mm (4)
i)	A		Overall length, Min	115
ii)	B		Width of ends	25 ± 1
iii)	C		Length of narrow, parallel-sided portion	33 ± 2
iv)	D		Width of narrow, parallel-sided portion	$6 + 0 - 0.4$
v)	E		Small radius	14 ± 1
vi)	F		Large radius	25 ± 2
vii)	G		Gauge length	25 ± 1
viii)	H		Initial distance between grips	80 ± 5
ix)	I		Thickness	That of the Pipe

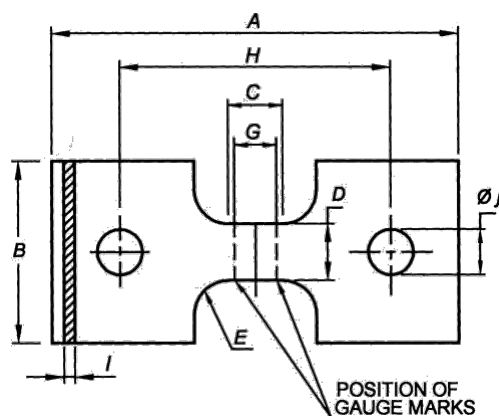

FIG. 6 TYPE 3 TEST PIECE

Table 15 Dimension of Type 3 Test Pieces
(Clause H-2.1.2)

SI No.	Symbol	Description	Dimension mm
(1)	(2)	(3)	(4)
i)	A	Overall length (min.)	250
ii)	B	Width of ends	100±3
iii)	C	Length of narrow, parallel-sided portion	25±1
iv)	D	Width of narrow, parallel-sided portion	25±1
v)	E	Radius	25±1
vi)	G	Gauge length	20±1
vii)	H	Initial distance between centres of loading pins	165±5
(viii)	I	Thickness	That of the pipe
ix)	J	Diameter of hole	30±5

H-2.2 Preparation of Test Pieces

Cut strips from the pipe as supplied, that is which has not been heated or flattened, so that their axis is parallel to the axis of the pipe and the positions from which the strips are taken conform to item (a) or item (b) below, as applicable:

- a) Pipes of nominal outside diameter less than or equal to 63 mm

Use lengths of pipe of approximately 150 mm

Cut strips from these various lengths, distributing them around the circumference from a generating line taken as the reference line

Unless otherwise specified, cut at least three strips from each sample so as to be able to take three test pieces (see Table 16).

Table 16 Recommended Number of Test Pieces [Clause H-2.2 (a)]

SI No.	Nominal Outside Diameter, d_n mm	Number of Sectors or Strips
(1)	(2)	(3)
i)	$15 \leq d_n < 75$	3
ii)	$75 \leq d_n < 280$	5
iii)	$280 \leq d_n < 450$	5
iv)	$d_n \geq 450$	8

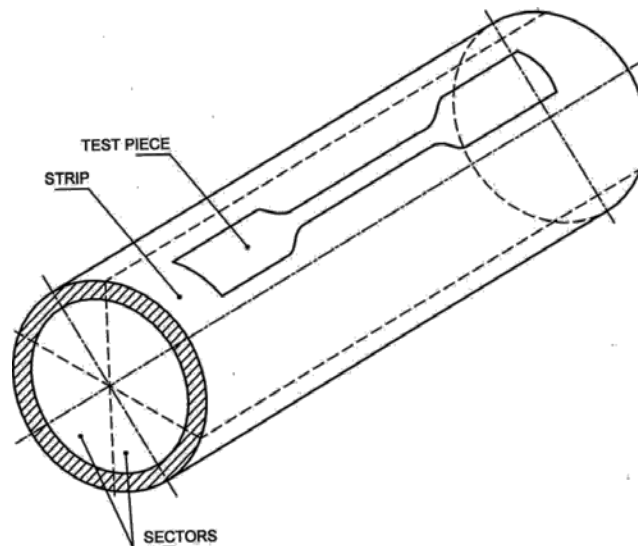

FIG. 7 PREPARATION OF TEST PIECES

- b) Pipes of nominal outside diameter greater than 63 mm

Use a length of pipe of approximately 150 mm.

Cut strips from the length in such a way that they are equally distributed around the circumference of the pipe as shown in Fig. 7.

Unless otherwise specified, divide the circumference of the pipe length into a number of sectors, depending on the diameter of the pipe as given in Table 16. Cut out one test piece per strip.

H-2.2.2 Selection of Test Pieces

The test pieces shall be taken from the centre of strips cut from the length of pipe in accordance with H-2.2.1 and with item (a) or item (b) below, as applicable.

- a) Pipes of wall thickness less than or equal to 12 mm

The test pieces shall be prepared by cutting with a die or machining to the following shape:

- type 1, for wall thicknesses less than or equal to 12 mm but greater than 5 mm;
- type 2, for wall thicknesses less than or equal to 5 mm.

- b) Pipes of wall thickness greater than 12 mm

Test pieces shall be prepared by machining. They shall be of type 1 or type 3.

H-2.3 Cutting Method

Use the cutting die (H-1.6) clean cutting edges, free from notches with a profile corresponding to that of the type 1 or type 2 test piece, depending on the thickness of the pipe.

Cut out the test piece at ambient temperature, applying the die cutter to the inner surface of the strip and exerting a continuous uniform pressure.

H-2.4 Machining Method

Produce the specimen by milling, where necessary using a milling jig.

The shape of the milling cutter and the machining conditions (speed of rotation and advance) are at the discretion of the operator. They shall however be chosen so as to avoid any heating of the test piece and deterioration of its surface such as cracks, scratches or other visible flaws.

H-3 CONDITIONING

Prior to testing, condition the test pieces at a temperature of (27 ± 2) °C for a period of not less than the time specified in Table 17, according to the thickness of the test piece.

Table 17 Conditioning Periods
(Clause H-3)

Sl No.	e_{Min} mm	Conditioning Period
(1)	(2)	(3)
i)	$e_{Min} < 3$	1 h \pm 5 min
ii)	$3 \leq e_{Min} < 8$	3 h \pm 15 min
iii)	$8 \leq e_{Min} < 16$	6 h \pm 30 min
iv)	$16 \leq e_{Min} < 32$	10 h \pm 1 h
v)	$32 \leq e_{Min}$	16 h \pm 1 h 30 min

The test pieces shall not be tested within a period of 15 h after the production of the pipes, except for manufacturing checks, unless otherwise specified in the referring standard.

H-4 TEST SPEED

The test speed, that is the speed of separation of the grips, shall depend on the thickness of the pipes, as specified in Table 18.

Table 18 Test Speed
(Clause H-4)

Sl No.	Nominal Wall Thickness of Pipe, e_n mm	Method of Preparation of Test Piece	Type of Test Piece	Test Speed mm/min
(1)	(2)	(3)	(4)	(5)
i)	$e_n \leq 5$	Die cutting or machining	Type 2	100
ii)	$5 < e_n \leq 12$	Die cutting or machining	Type 1	50
iii)	$e_n > 12$	Machining	Type 1	25
iv)	$e_n > 12$	Machining	Type 3	10

H-5 PROCEDURE

Carry out the following procedure at a temperature of (27 ± 2) °C.

- Measure, to within 0.01 mm, the width and minimum thickness of the central part of the test piece between the gauge marks. Calculate the minimum cross-sectional area.
- Place the test piece in the tensile-testing machine in such a way that the axis of the test piece coincides more or less with the direction of the tensile force. Clamp the grips uniformly and tightly to avoid any slippage of the test piece.
- Adjust the test speed to the value specified and set the machine in motion.
- Record the stress/strain curve up to the rupture of the test piece and record on this curve the gauge length at rupture, or note directly the value of the gauge length after rupture.

Discard any test pieces which slip in the grips, those which break at one of the shoulders and those which deform, thus changing the width of the shoulders, and retest an identical number of test pieces.

H-6 EXPRESSION OF RESULTS

Calculate, for each test piece, the elongation at break, using the following formula:

$$E = \frac{L_1 - L_0}{L_0} \times 100$$

Where

E = elongation at break expressed as a percentage;

L₀ = initial gauge length of the test piece, expressed in mm; and

L₁ = length at break, expressed in mm.

The above average value (arithmetic mean) of all the test pieces shall be obtained and reported.

ANNEX J

(Clause 8.10)

METHOD OF PREPARATION OF LONGITUDINALLY NOTCHED TEST PIECES FOR SLOW CRACK GROWTH RATE TEST

J-1 APPARATUS

The apparatus shall consist of a milling machine having a horizontal mandrel rigidly fixed to the bed to enable a pipe to be securely clamped to give a straight specimen. The mandrel shall support the pipe bore beneath and along the full length of the notch to be machined.

The milling cutter, mounted on a horizontal arbor, shall be a 60° included angle 'v' cutter, 12.5 mm wide having a cutting rate of 0.010 ± 0.002 mm/rev/tooth, for example a cutter with 20 teeth rotating at 700 rev/min traversed along at a speed of 150 mm/min has a cutting rate of $[150 / (20 \times 700)] = 0.011$ mm/rev/tooth. The milling cutter shall be carefully protected against damage. It shall not be used for any other material or purpose and shall be replaced after 100 m of notching.

J-2 TEST PIECE

A sample of pipe having free length between the end fittings equal to 10 times the outside diameter but neither less than 250 mm nor greater than 750 mm shall be taken for testing from each pipe to be tested.

J-3 PROCEDURE

J-3.1 The minimum pipe wall thickness shall be located and marked for machining an initial notch. The positions shall be marked for machining three additional notches equally spaced around the pipe circumference at the same position along the specimen as the initial notch.

J-3.2 The average minimum wall thickness shall be determined from measurements taken at either end of the specimen in line with a position of the initial notch.

J-3.3 For pipes having a wall thickness greater than 50 mm, the notch shall initially be machined with a slot drill of 15 mm to 20 mm diameter to leave approximately 10 mm to be removed by the 'v' cutter when machining in accordance with J-3.4 or J-3.5.

J-3.4 The initial notch (see J-3.1) shall be machined by climb milling to depth so as to produce a pipe wall ligament of thickness between 0.78 and 0.82 times the minimum specified wall thickness of the pipe (see Fig. 8).

NOTE — To achieve a remaining ligament within the required tolerance range, it is advisable to aim for a remaining ligament at the top of the tolerance range. This is because the pipe wall can move due to release of residual stresses, resulting in a deeper than anticipated notch.

The length of the notch, at full depth, shall be equal to the pipe outside diameter ± 1 mm.

J-3.5 An additional notch shall be machined at each of the three positions marked in accordance with J-3.1 so that each notch has an identical ligament thickness to that of the initial notch and the ends of each notch are aligned circumferentially with those of the initial notch as shown in Fig. 8 and Fig. 9.

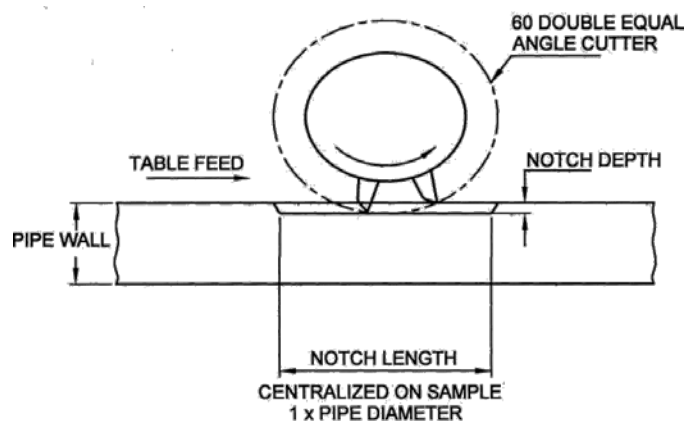

FIG. 8 NOTCH METHOD

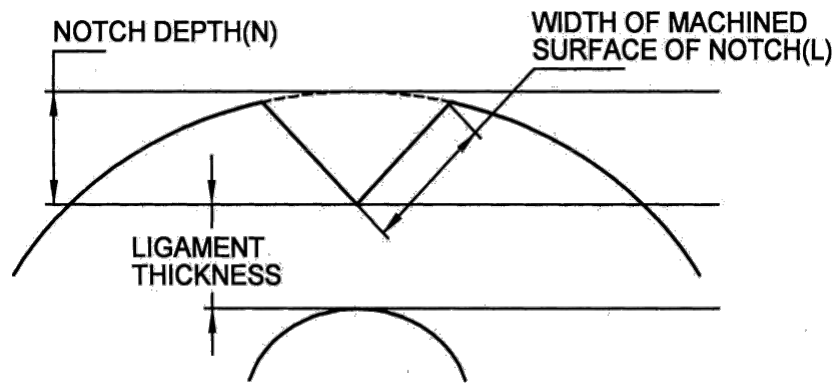

FIG. 9 MEASUREMENT TO CALCULATE NOTCH DEPTH

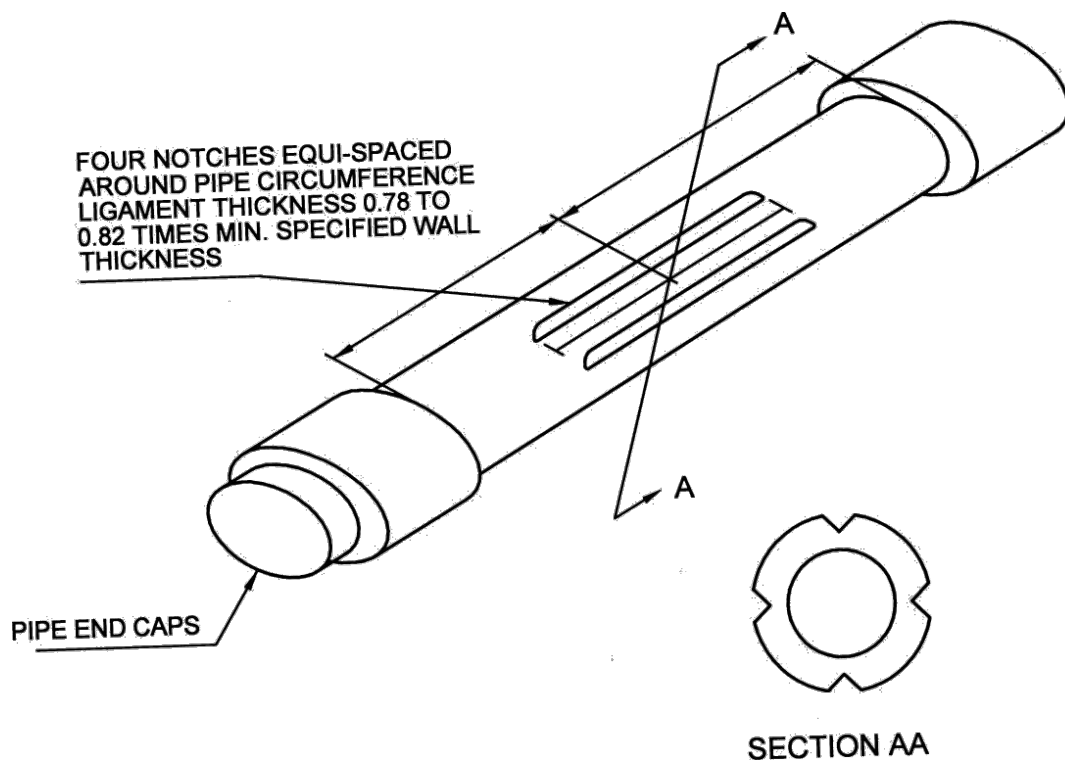

FIG. 10 PIPE TEST PIECE

J-4 MEASUREMENT OF NOTCH DEPTH

On completion of the pressure test, the test piece shall be removed from the water tank and allowed to cool to 27 ± 2 °C. A section of pipe shall be cut out from around the position of each notch.

The notch shall be opened up to give clear access to one of the machined surfaces of the notch. The width L

(mm) of the machined surface of the notch shall be measured to an accuracy of ± 0.1 mm with a microscope or other suitable means as shown in Fig. 10.

The notch depth N (mm) shall be calculated from the equation.

$$N = 0.5 [d_{em} - (d_{em}^2 - L^2)^{1/2}] + 0.86 L$$

Where

d_{em} = measured mean pipe outside diameter, in mm; and

L = width of machined surface of notch, in mm.

The ligament thickness shall be calculated from the notch depth. For acceptance, each notch shall be in accordance with J-3.4.

Nepal Council for Standardization (NCS)

ने.गुण.४०:२०७९, Polyethylene Pipes for Water Supply - Specification

अध्यक्ष : माननीय श्री दिलेन्द्रप्रसाद बडू, मन्त्री, उद्योग, वाणिज्य तथा आपूर्ति मन्त्रालय

उपाध्यक्ष : श्री अर्जुन प्रसाद पोखरेल, सचिव, उद्योग, वाणिज्य तथा आपूर्ति मन्त्रालय

सदस्यहरु

सि.नं.	नाम	पद	संस्था
१.	श्री चन्द्रकला पौडेल	सह सचिव	उद्योग, वाणिज्य तथा आपूर्ति मन्त्रालय
२.	डा. नारायण प्रसाद रेग्मी	सह सचिव	उद्योग, वाणिज्य तथा आपूर्ति मन्त्रालय
३.	श्री केशवकुमार शर्मा	सह सचिव	भौतिक पूर्वाधार तथा यातायात मन्त्रालय
४.	श्री शवनम सिवाकोटी अर्याल	सह सचिव	कृषि तथा पशुपन्छी विकास मन्त्रालय
५.	श्री कोशलचन्द्र सुवेदी	सह-प्राध्यापक	कानून, न्याय तथा संसदीय मामिला मन्त्रालय
६.	श्री इन्दु विक्रम जोशी	सह सचिव	शिक्षा विज्ञान तथा प्रविधि मन्त्रालय
७.	प्रा.डा. दीपक प्रसाद सुवेदी	प्राध्यापक	काठमाडौं विश्वविद्यालय
८.	डा. अजय कुमार झा	सह-प्राध्यापक	भौतिक शास्त्र, त्रिभुवन विश्वविद्यालय
९.	श्री भरत राज आचार्य	-	नेपाल उद्योग वाणिज्य महासंघ
१०.	श्री दीपक श्रेष्ठ	उपाध्यक्ष	नेपाल चेम्बर अफ कमर्स
११.	श्री ध्रुव बहादुर शाह	-	नेपाली उपभोक्ता संरक्षण महासंघ

सदस्य सचिव

श्री दीनानाथ मिश्र, महानिर्देशक, नेपाल गुणस्तर तथा नापतौल विभाग

ने.गुण. ४०: २०७९ Polyethylene Pipes for Water Supply - Specification विषयक प्राविधिक
समितिका सदस्यहरु

सि.नं.	नाम	पद	संस्था
१.	श्री विश्ववावु पुडासैनी	महानिर्देशक	ने. गुण. तथा ना.तौ. विभाग
२.	श्री दीनानाथ मिश्र	उप-महानिर्देशक	ने. गुण. तथा ना.तौ. विभाग
३.	श्री कुमारी ज्योती जोशी	उप-महानिर्देशक	ने. गुण. तथा ना.तौ. विभाग
४.	श्री प्रभात कुमार सिंह	उप-महानिर्देशक	ने. गुण. तथा ना.तौ. विभाग
५.	डा.चण्डिका प्रसाद भट्ट	सि.डि.के.ई.	उद्योग वाणिज्य तथा आपूर्ति मन्त्रालय
६.	श्री आलोक कुमार मिश्र	निर्देशक	ने. गुण. तथा ना.तौ. विभाग
७.	श्री उदय कुमार गुप्ता	निर्देशक	ने. गुण. तथा ना.तौ. विभाग
८.	श्री किशु मानन्धर	निर्देशक	ने. गुण. तथा ना.तौ. विभाग
९.	श्री अनिल शाक्य	निर्देशक	ने. गुण. तथा ना.तौ. विभाग
१०.	श्री सुरत कुमार वंम	सि.डि.ई.	खानेपानी तथा ढल व्यवस्थापन विभाग
११.	श्री भरतराज आचार्य	सभापति	उ.समिति, नेपाल उद्योग वाणिज्य महासंघ
१२.	श्री शरद शर्मा	-	नेपाल प्लाष्टिक उत्पादक संघ
१३.	श्री ईश्वर प्रसाद	ए. मेनेजर	नेपाल वाटर सप्लाई कोर्पोरेशन
१४.	श्री देवेन्द्र साहू	ए.जी.एम.	पन्चकन्या प्लाष्टिक एण्ड पाईप ई.प्रा.लि.
१५.	श्री रविन्द्र झा	निर्देशक	हिलटेक प्लाष्टिक एण्ड पाईप ई.प्रा.लि.
१६.	श्री माधव तिमिल्सिना	अध्यक्ष	उपभोक्ता अधिकार अनुसन्धान मंच
१७.	श्री शुक्रराज अधिकारी	केमिष्ट	ने. गुण. तथा ना.तौ. विभाग
१८.	श्री सुजित कुमार चौधरी	प्रा.स.	ने. गुण. तथा ना.तौ. विभाग

नेपाल गुणस्तर तथा नापतौल बिभाग

बालाजु, काठमाडौं, नेपाल

फोन नं. ०१-४३५०४४५, ४३५०४४७, ४३५०७२९, ४३५०८१८, ४३८५७२३

फ्याक्स नं. +९७७-०१-४३५०६८९

Email: nbsm@nbsm.gov.np

पो.ब.नं. ९८५

सर्वाधिकार सुरक्षित